

AS85049/31, MS3416 E and M83723/15N "E" Nuts



"E" Nuts

Glenair Connector Designator A

MIL-DTL-5015 Series 3400,
MIL-DTL-26482 Series 2,
AS81703 Series 3,
MIL-DTL-83723 Series I &
III, 40M39569, DEF 5326-3,
EN 2997, EN 3646,
ESC 10, ESC 11, LN 29504,
NFC93422 Series HE302,
PAN 6432-1, PAN 6432-2,
PATT 602

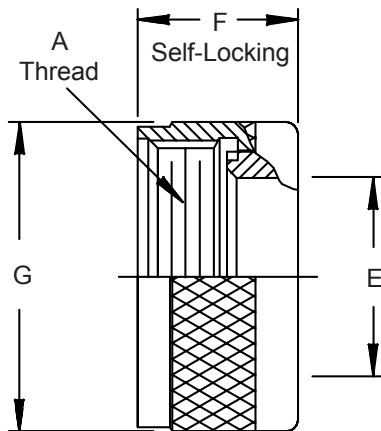

M85049/31 S 22 N

Basic Part No. _____
S = Self-Locking
Use Dash (-) for
Non-Self Locking
Finish
A = Black Anodize
N = Electroless Nickel
W = 1,000 Hr. Cadmium Olive
Drab Over Electroless Nickel
Shell Size

MS3416-10 E A

Basic Part No. _____
(Non-Self-Locking Only)
Dash No. _____
Style _____
SUPERCEDED SPEC.
Material and Finish Designator
A = Aluminum, 500 Hour Cad. Olive
Drab Over Electroless Nickel
C = Aluminum, Cadmium Olive Drab
G = Aluminum, Black Anodize
N = Aluminum, Electroless Nickel

M83723/15N-10 A

Basic Part No. _____
(Non-Self-Locking Only)
Dash No. _____
SUPERCEDED SPEC.
Finish Designator
A = Non-Conductive, Black Anodize
R = Conductive, Electroless Nickel

TABLE I

Shell Size	A Thread Class 2B	E Dia Max	F Max	G Dia Max
3	.562 - 24 UNEF	.270 (6.9)	--	--
8	.500 - 20 UNF	.270 (6.9)	.710 (18.0)	.885 (22.5)
10	.625 - 24 UNEF	.375 (9.5)	.710 (18.0)	1.010 (25.7)
12	.750 - 20 UNEF	.511 (13.0)	.710 (18.0)	1.135 (28.8)
14	.875 - 20 UNEF	.585 (14.9)	.710 (18.0)	1.260 (32.0)
16	1.000 - 20 UNEF	.710 (18.0)	.710 (18.0)	1.385 (35.2)
18	1.062 - 18 UNEF	.789 (20.0)	.710 (18.0)	1.510 (38.4)
20	1.188 - 18 UNEF	.914 (23.2)	.710 (18.0)	1.635 (41.5)
22	1.313 - 18 UNEF	1.039 (26.4)	.710 (18.0)	1.760 (44.7)
24	1.438 - 18 UNEF	1.154 (29.3)	.710 (18.0)	1.885 (47.9)
28	1.750 - 18 UNS	1.389 (35.3)	.890 (22.6)	2.135 (54.2)
32	2.000 - 18 UNS	1.635 (41.5)	.890 (22.6)	2.395 (60.8)
36	2.250 - 16 UN	1.850 (47.0)	.890 (22.6)	2.635 (66.9)
40	2.500 - 16 UN	2.065 (52.5)	.890 (22.6)	2.885 (73.3)
44	2.750 - 16 UN	2.320 (58.9)	.890 (22.6)	3.135 (79.6)
48	3.000 - 16 UN	2.570 (65.3)	.890 (22.6)	3.385 (86.0)
61	1.500 - 18 UNEF	1.194 (30.3)	--	--

1. For complete dimensions see applicable Military Specification.
2. Metric dimensions (mm) are indicated in parentheses.