



## M83538/9S Adapters/Extenders

For Use With  
MIL-C-83538/4

**M83538/9S 09**

Basic Part No.

Shell Size

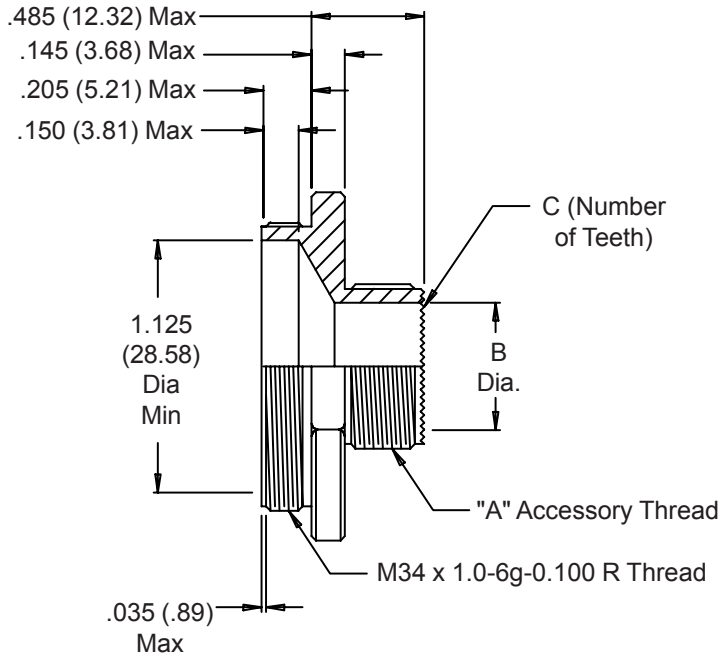
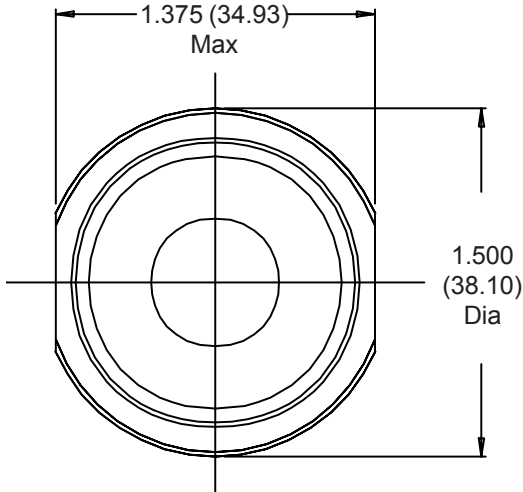

**TABLE I**

Shell Size	"A" Accessory Thread	B Dia ±.005 (0.13)	C Number of Teeth
09	M12x1.0-6g 0.100R	.332 (8.18)	12
11	M15x1.0-6g 0.100R	.440 (11.18)	16
13	M18x1.0-6g 0.100R	.559 (14.20)	20
15	M22x1.0-6g 0.100R	.716 (18.19)	24
17	M25x1.0-6g 0.100R	.834 (21.18)	28
19	M28x1.0-6g 0.100R	.952 (24.18)	32
21	M31x1.0-6g 0.100R	1.070 (27.18)	36
23	M34x1.0-6g 0.100R	1.188 (30.18)	40

1. For complete dimensions see applicable Military Specification.
2. Material is corrosion resistant steel.
3. Metric dimensions (mm) are indicated in parentheses.