



1.0/2.3 Series Subminiature RF Connectors

General Description

Delta 1.0 / 2.3 series jacks are compact, high-performance connectors that mate with all five standard types of 50 ohm 1.0 / 2.3 series plugs.

Designed to meet all applicable CECC and DIN requirements, they offer good electrical performance up to 10 GHz.

These connectors are ideal for use in rack-and-panel applications with appropriate slide-on mating plugs.

Current configurations include direct-solder bulkhead jacks for semi-rigid cable, along with two- and four-hole flange panel jacks with post contacts. New types are being added to our product line, so please call with your requirements for other 1.0 / 2.3 configurations.

1.0/2.3 Configurations

Straight P.C. Board Jack Receptacle	1
Panel Jack Receptacles.....	1
Bulkhead Cable Jacks.....	2

1.0/2.3 Specifications*

Jack Interface**

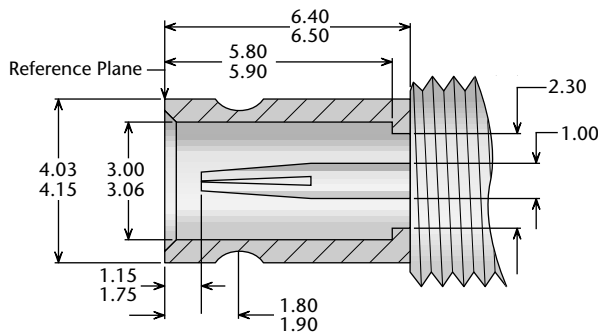

**Some proportions altered to illustrate detail. Dimensions in mm.

Electrical:

Nominal Impedance: 50 ohms.

Frequency Range: DC-10 GHz.

Voltage Rating: 250 volts RMS (dependent on cable).

Dielectric Withstanding Voltage: 750 volts RMS.

Insulation Resistance: 1,000 megohms.

Materials/Finishes:

Insulators: Teflon per ASTM D1710.

Female Contacts: Beryllium Copper per ASTM B196.

Contact Plating: Gold per MIL-G-45204.

Gaskets: Silicone rubber per ZZ-R-765, Class II, Grade 50.

Other Metal Parts: Brass per ASTM B16, gold plated per MIL-G-45204.

All other specifications are in accordance with the latest issues of CECC 22 230, DIN 41626, or DIN 47297, or other applicable specifications, and interfaces are in accordance with IEC 169-29.

*These specifications are typical and may not apply to all connectors. Detailed specifications for individual connectors are available on request.

Printed-Circuit Board Jack Receptacle

Figure 1
(Straight through-hole mount)

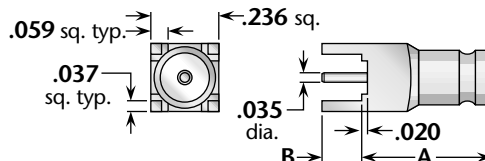

Figure	Dimensions		Max. Board	Mounting Figure	Plating		Delta P/N
	A	B			Body	Contact	
1	.433	.138	.100	PCB06	Gold	Gold (C)	4267-000-G91P-1

Panel Jack Receptacles—Post Contact

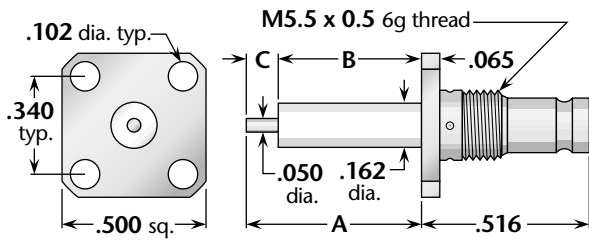

Figure 1 (1/2" square flange)

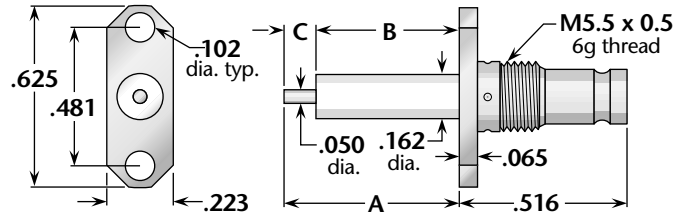
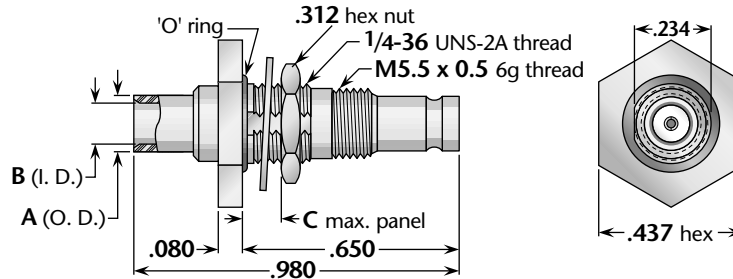

Figure 2 (2-hole flange)

Figure	Dimensions			Plating		Delta P/N
	A	B	C	Body	Contact	
1	.705	.590	.115	Gold	Gold (C)	4258-000-G051
1	.250	.150	.100	Gold	Gold (C)	4258-000-G051-10
2	.705	.590	.115	Gold	Gold (C)	4258-000-G921-2
2	.250	.150	.100	Gold	Gold (C)	4258-000-G921-3

Bulkhead Jacks—Direct Solder for Semi-Rigid Cable



Cable Group	Dimensions			Mounting Figure	Plating		Delta P/N
	A	B	C		Body	Contact	
13	.184	.145	.125	67	Gold	Gold	4217-031-G673
14	.120	.088	.125	67	Gold	Gold	4217-025-G673

Assembly Procedure

- 1) Trim cable as shown. Remove any burrs from jacket and center conductor. Tin center conductor.

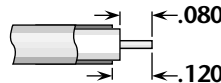

- 2) Solder contact to center conductor, with end of contact flush with cable dielectric. Remove any excess solder from outside of contact.

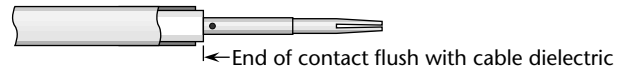

- 3) Insert cable into body until end of cable jacket stops against internal shoulder. Solder cable jacket to body.

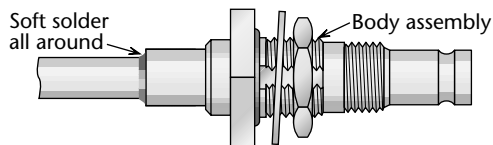

Cable Groups

13	.141" semi-rigid; RG-402; M17/130	14	.085" semi-rigid; RG-405; M17/133
----	-----------------------------------	----	-----------------------------------

Receptacles also available with other contact / insulator configurations. • (C) in contact plating column indicates captive contact.